



COMUNE DI LATINA

**REGOLAMENTO PER L'ESECUZIONE DI LAVORI DI SCAVO E RIPRISTINO  
NELLE AREE PUBBLICHE O DI USO PUBBLICO**

**ALLEGATO**

**SCHEMI GRAFICI**

SCHEMI GRAFICI

MODALITA' TIPO DI RIPRISTINO  
PAVIMENTAZIONE STRADALE

STRADE CON CARREGGIATA SINO A 4,00 MT.



figura 1      scavo longitudinale alla carreggiata



figura 2      scavo trasversale alla carreggiata

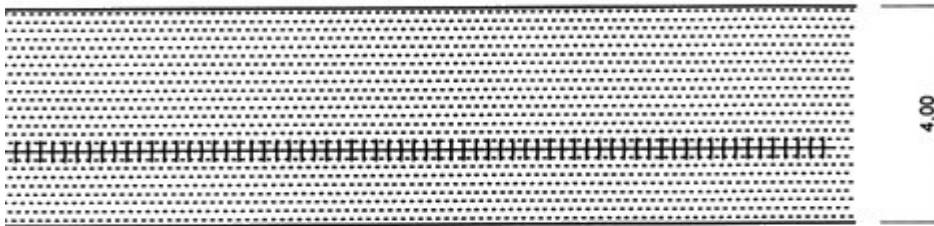

figura 3      scavo trasversale alla carreggiata

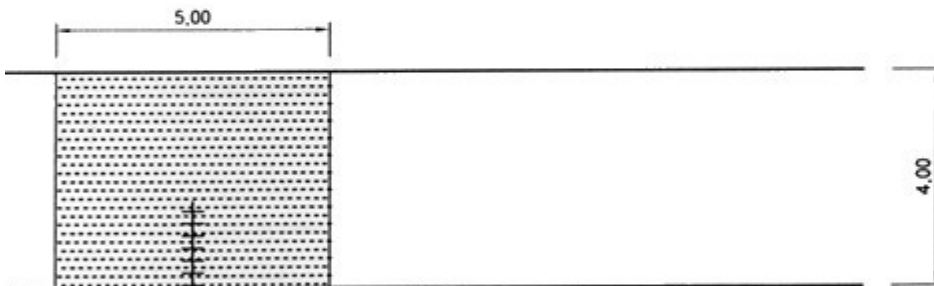

figura 4 doppio scavo trasversale alla carreggiata

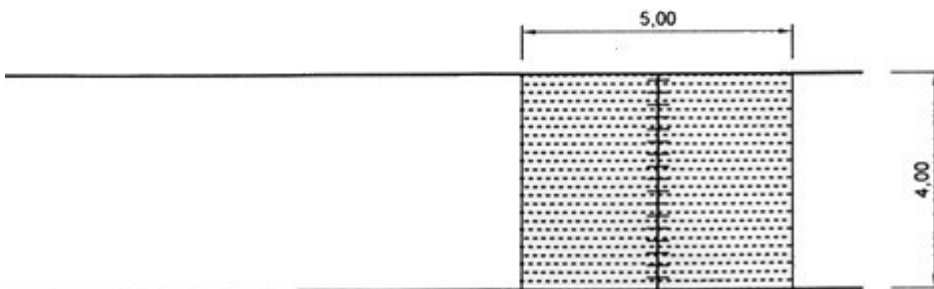

figura 5 scavi multipli

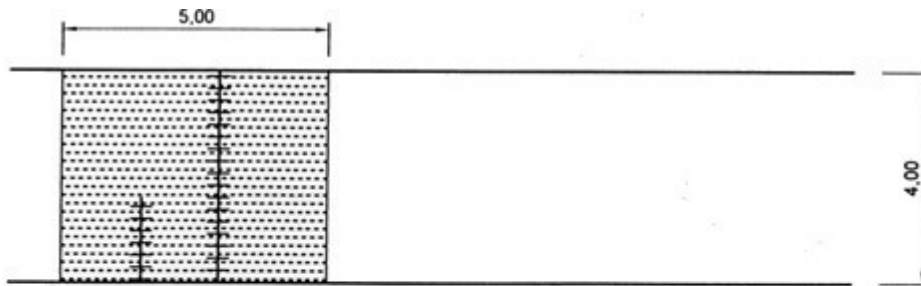

figura 6 scavi multipli

# MODALITA' TIPO DI RIPRISTINO PAVIMENTAZIONE STRADALE

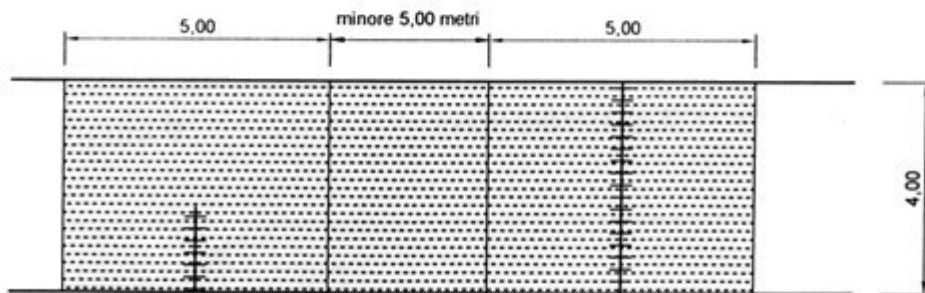
STRADE CON CARREGGIATA OLTRE 4,00 MT.

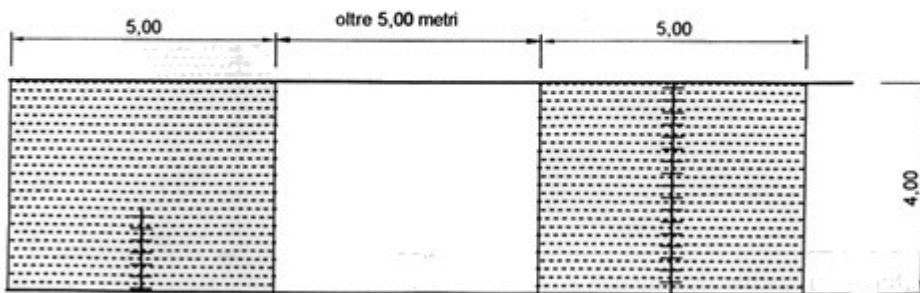
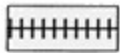

area di scavo

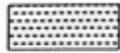

area di ripristino



figura 7

scavo longitudinale alla carreggiata

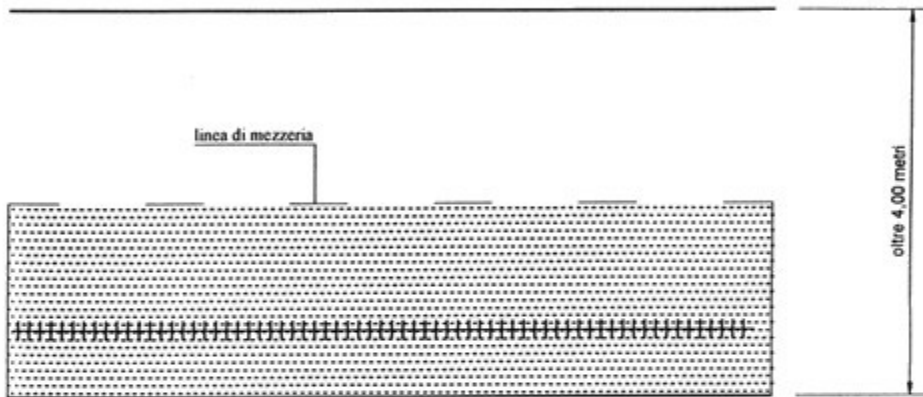

figura 8

scavo trasversale alla carreggiata



figura 9 scavo trasversale alla carreggiata

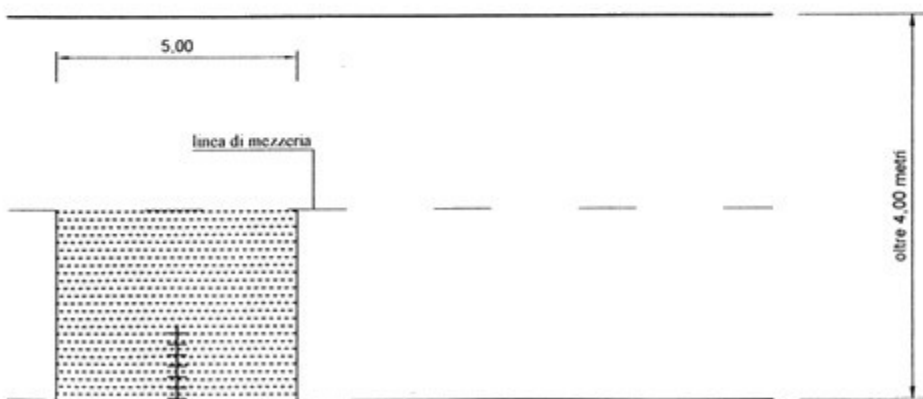

figura 10 doppio scavo trasversale alla carreggiata

# MODALITA' TIPO DI RIPRISTINO PAVIMENTAZIONE STRADALE

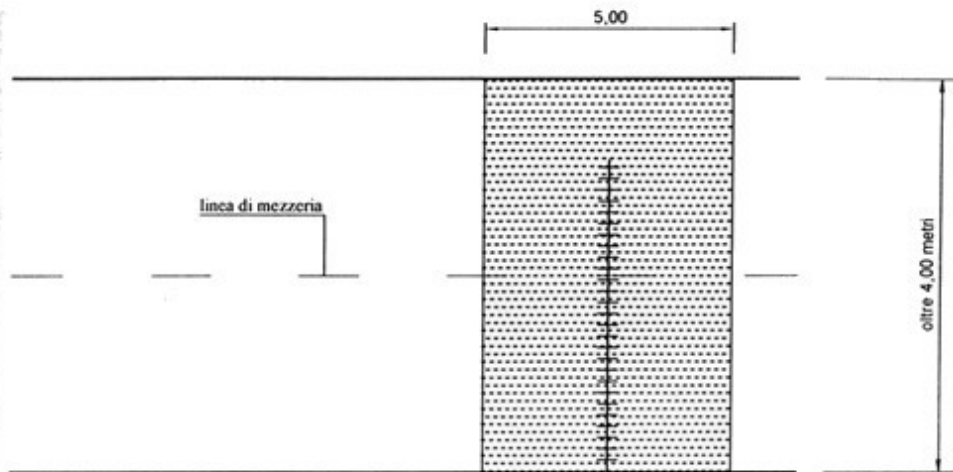
STRADE CON CARREGGIATA OLTRE 4,00 MT.

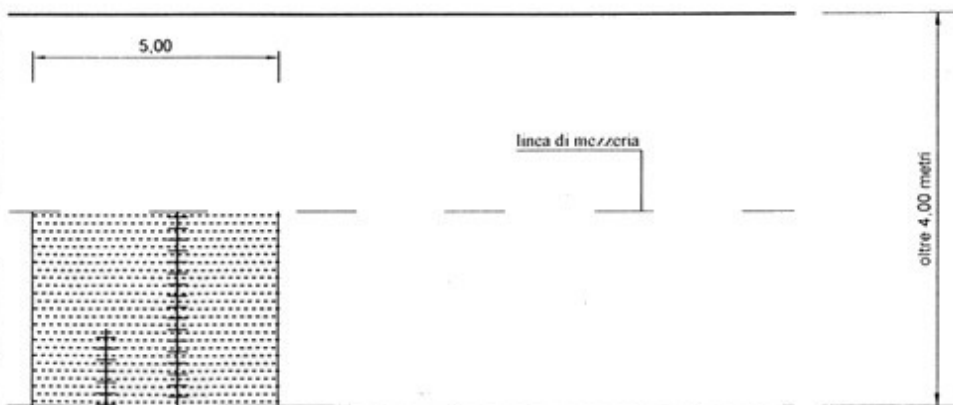

area di scavo

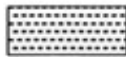

area di ripristino



figura 11

scavo longitudinale e trasversale

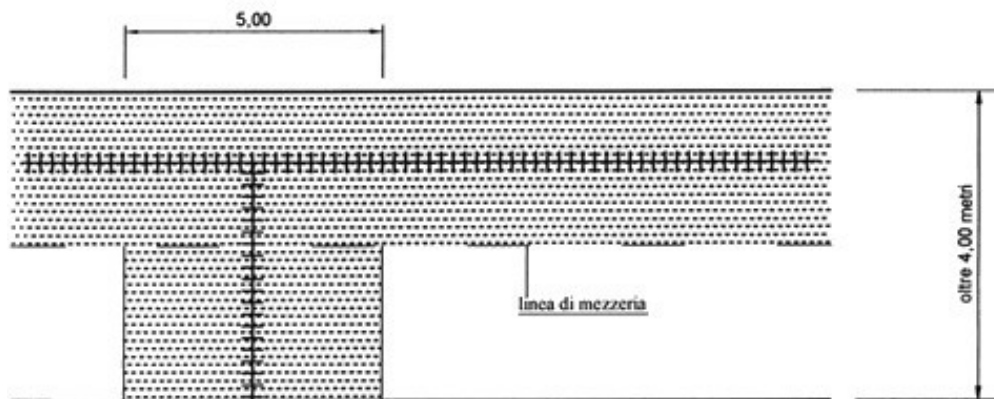

figura 12

scavi multipli



figura 13      scavi multipli

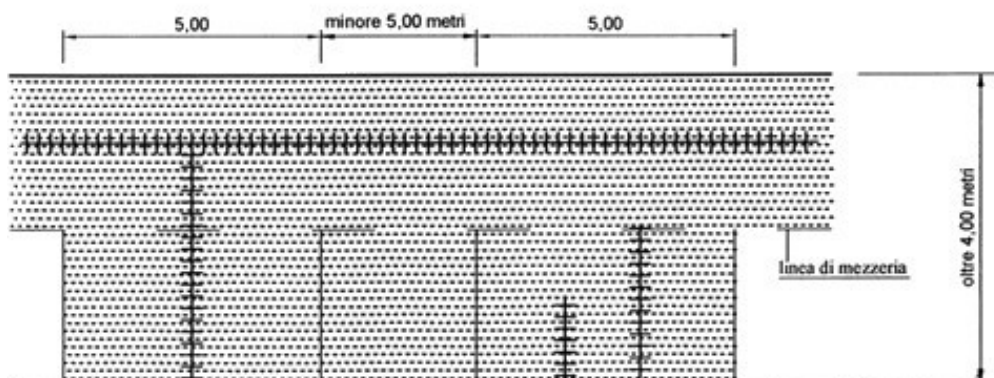

figura 14      scavo al centro della strada

SCHEMA DI SEZIONE STRADALE TIPO  
IN CONGLOMERATO BITUMINOSO  
PRIMA DELL'INIZIO DELLO SCAVO

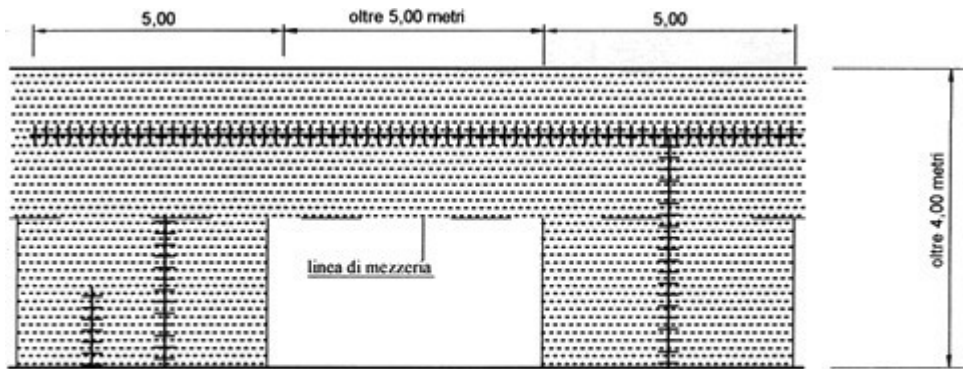
1

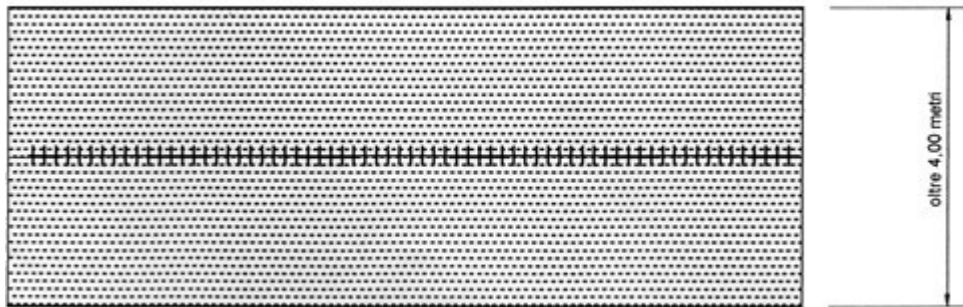
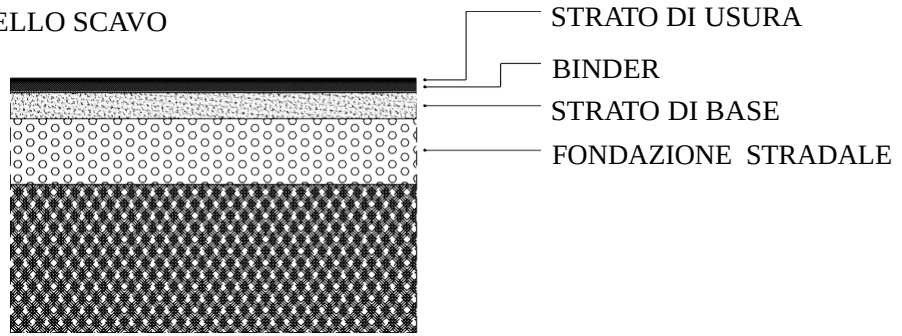

Taglio della pavimentazione  
bituminosa con apposita  
macchina operatrice a lama rotante

2

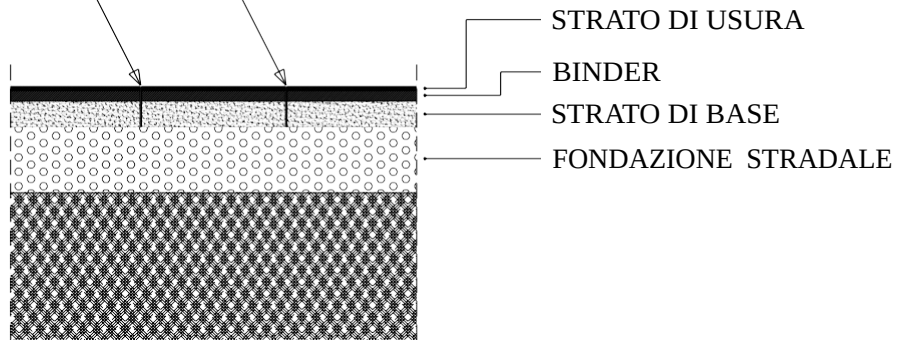

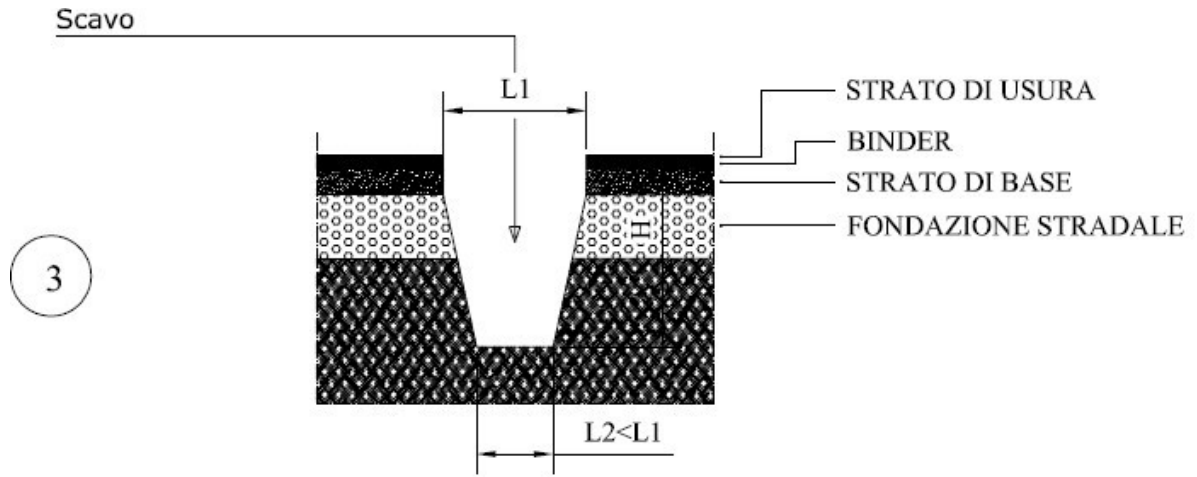

Riempimento dello scavo con misto cementato dosato a q.l. 1,00 di cemento al mc Impastato

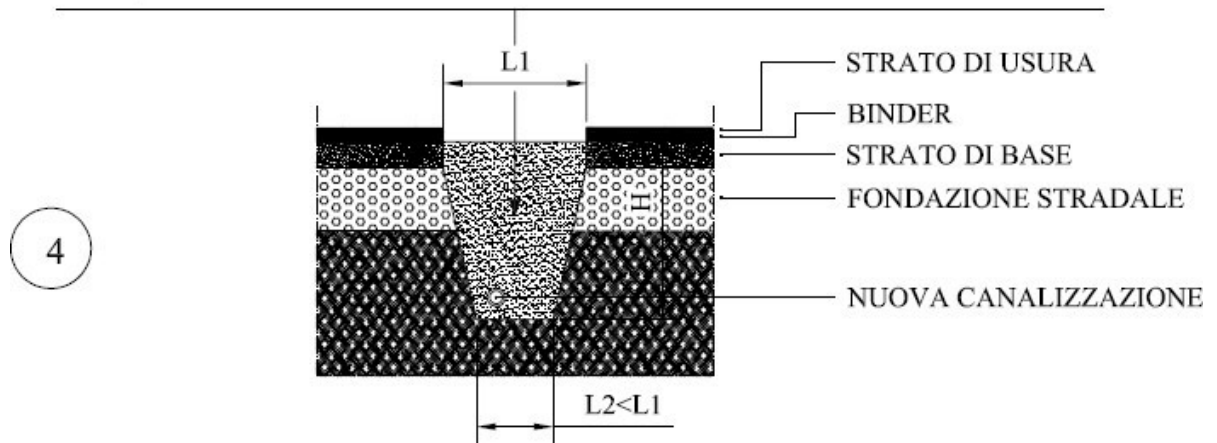

Ripristino provvisorio:

taglio della pavimentazione  
bituminosa con apposita  
macchina operatrice a lama rotante

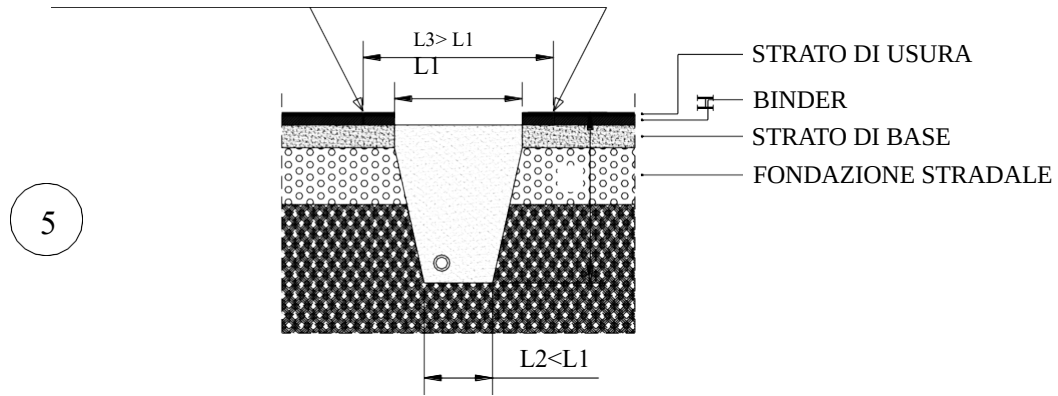

Ripristino provvisorio:  
Preparazione per la stesa del manto  
bituminoso tipo "binder"

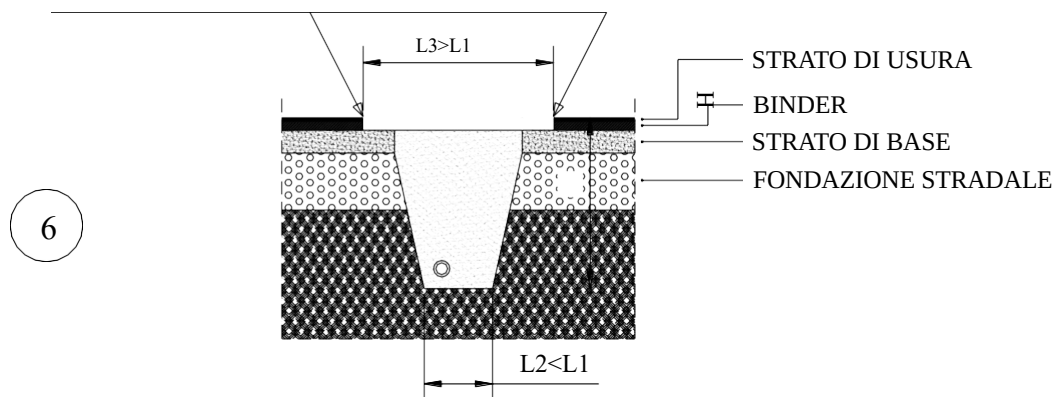

Ripristino provvisorio:  
Posa in opera del manto bituminoso tipo "binder"

7

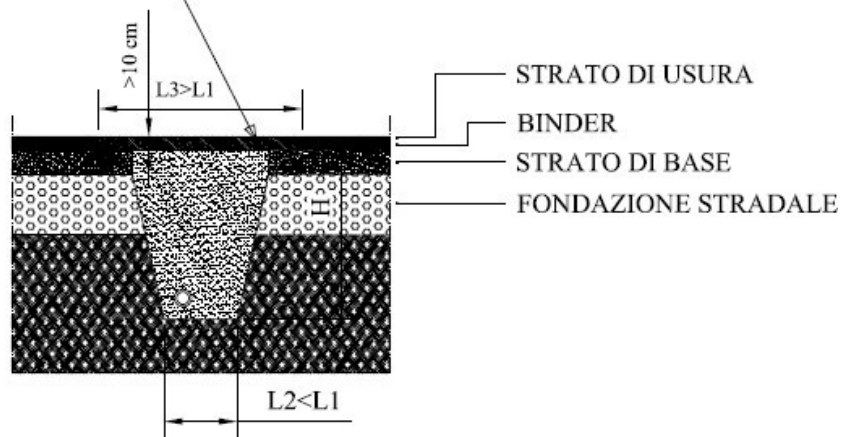

Ripristino definitivo:  
taglio della pavimentazione bituminosa con apposita  
macchina operatrice a lama rotante

8

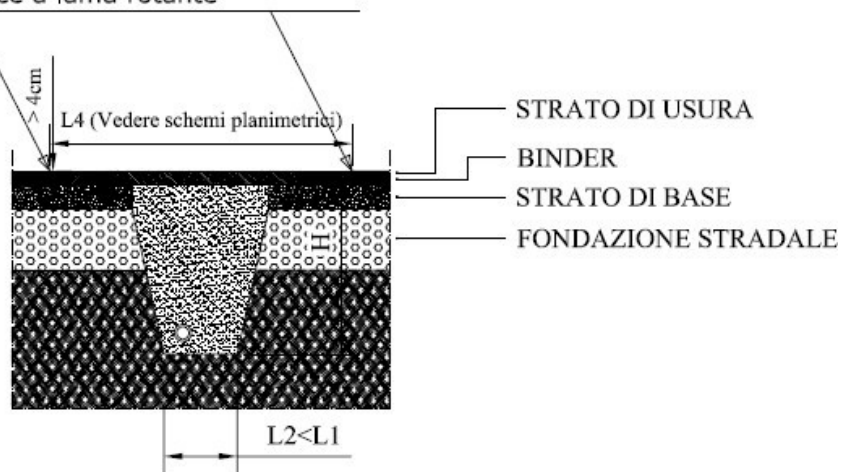

Ripristino definitivo:  
 fresatura della pavimentazione bituminosa con apposita  
 macchina operatrice e posa in opera di emulsione bituminosa

9

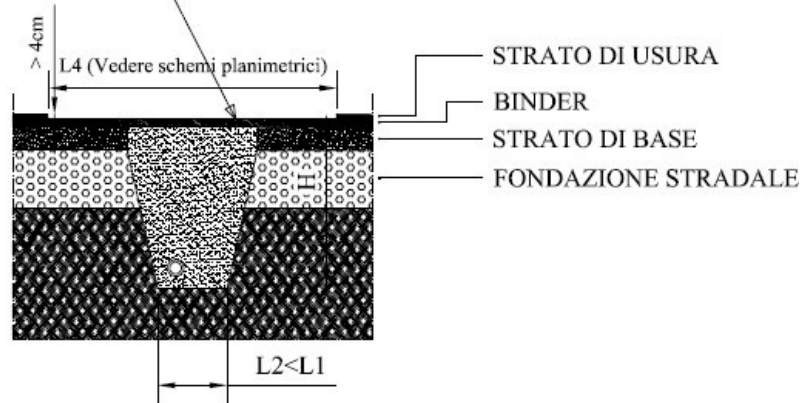

Ripristino definitivo:  
 manto di usura in conglomerato bituminoso chiuso, steso in opera a mano  
 e/o con macchina vibrofinitrice opportunamente rullato  
 per uno spessore compresso minimo di cm. 4

10

